



RAM

110 CONVERTIBLE by GARLOCK EQUIPMENT

RUBBERIZED ASPHALT MELTER

The 110 Convertible RAM is the latest innovation to help contractors reach restricted access areas like high rises, narrow ally's, parking garages, garden areas or construction sites. Built specifically to melt heat-sensitive rubberized waterproofing materials, the 110 Convertible RAM has all of the features of the standard RAM's but with a portable service rack unit that detaches from the main transport trailer. You are able to move just the heating tank to where you are working.

Modular design allows for separation of the heating unit from the transport trailer in 3 easy steps.



1. Lower service rack unit.



2. Roll heating tank onto service rack.



3. Detach service rack from transport trailer.



Wheel service rack into freight elevators or through tight access areas.

GARLOCKTM
EQUIPMENT COMPANY

Where Better Engineering Comes Out On Top

RAM



110 CONVERTIBLE by GARLOCK EQUIPMENT

RUBBERIZED ASPHALT MELTER



- 8 caster wheels distribute weight
- Built-in wheel brakes
- Fits in freight elevators
- Hoist to roof
- Tank unit can mount permanently on truck



SPECIFICATIONS

Capacity110 gals.
 Gals. Per Hour100 gals.
 Heat & Pour.....45-60 min.
 Temperature ControlsStandard
 Fume Control.....Standard
 Engine Option: Gas8.5 hp Kohler
 Diesel6.25 hp Kubota

Weights:
 Full Package2600 lbs. empty
 Tank on Service Rack1800 lbs. empty
 Service Rack only200 lbs. empty



- 1). Built-in Fume Control system
- 2). Gas or diesel engine options
- 3). Diesel-fired burner with auto controls
- 4). 15 gallon diesel tank for burner

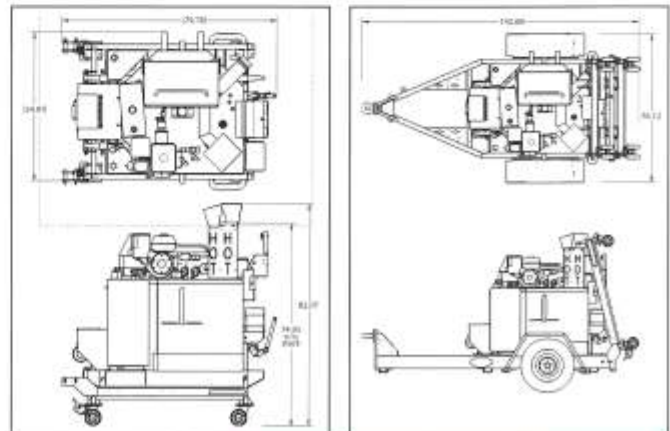

Distributed by:



465 Lucas Ave, Winnipeg,
 MB. R3C 2E6
 Ph (204) 774-5079
 Fax (204) 775-6142
 email: info@frsmb.com

